

CABLE 130 RF: RF CABLE ASSEMBLY, HIROSE W.FL PLUG + RP SMA BULKHEAD JACK + 0.81MM CABLE - 3GHz

SPECIFICATIONS

1. HIROSE W.FL PLUG (W.FL-LP-040).
2. ϕ 0.81MM COAXIAL CABLE, GRAY.
3. RP SMA ST BULKHEAD JACK(C20ABWS178003B), GOLD

NOTES:

1. THE ORIENTATION OF CONNECTORS ON DRAWING IS FOR REFERENCE ONLY, IF THE ORDER IS LEFT BLANK THE CONNECTOR WILL NOT HAVE FIXED ORIENTATION.

2. FIXED ORIENTATION IS POSSIBLE FOR CABLE LENGTH 25MM TO 220MM. PLEASE SPECIFY THE FIXED ORIENTATIONS FROM THE ORDER CODE (F1, F2, ETC)

3. CONTACT GRAD CONN IF THE ORIENTATION YOU REQUIRE IS NOT SHOWN.

4. WORKING FREQUENCY RANGE: DC-3GHz

USAGE PRECAUTIONS: CABLES USING 'MICRO' COAX ARE DELICATE:
 (i) HANDLE WITH CARE.
 (ii) DO NOT TWIST; APPLY EXCESSIVE FORCES OR SHARP BENDS TO THE CABLE. DO NOT FORCEFULLY DEFORM WIRES.
 (iii) CONSULT CONNECTOR MANUFACTURER'S DATASHEETS FOR DETAILED NOTES ON HANDLING INSTRUCTIONS.

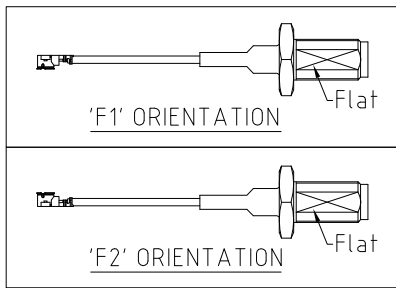
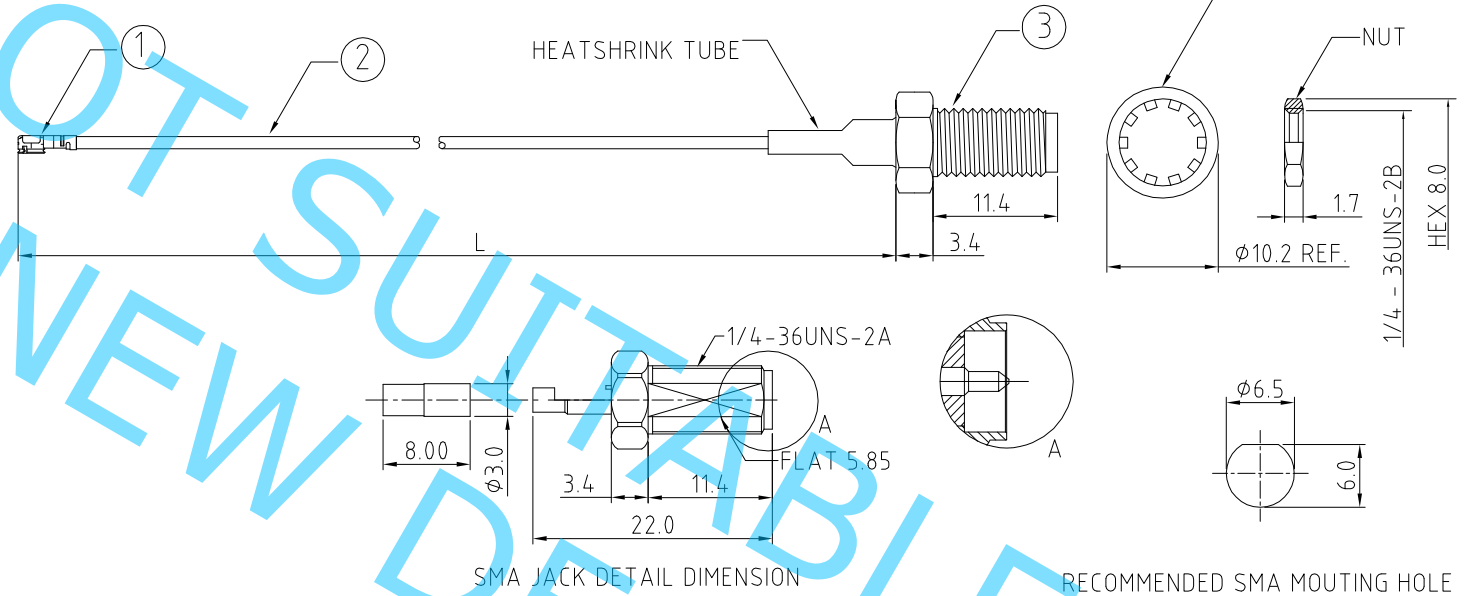

HOW TO ORDER
 CABLE 130 RF - XXX - X - XX

"L" LENGTH IN MM
 eg: 100MM = 0100
 (MIN. 025-MAX.400)
 STANDARD = 100, 150, 200)
 Tolerance: <50mm : ± 2 mm.
 51-200mm : ± 5 mm.
 201-400mm : ± 7 mm.

WASHER AND NUT OPTIONS:
 BLANK = SEPERATELY PACKED (STANDARD)
 A = ASSEMBLED WITH CONNECTOR

BLANK = DOES NOT HAVE A FIXED ORIENTATION
 F1 = HIROSE CONNECTION DOWN (L=25-220MM)
 F2 = HIROSE CONNECTION UP (L=25-220MM)
 (SEE NOTES 1, 2, 3 AND DIAGRAMS FOR MORE INFORMATION)

REV. DATE & DRN
 TO 21/10/11 - NYW RELEASE

Scale: NTS	THIRD ANGLE	Unstated X	Tolerances: ± 0.2	Material
Drawn: NYW		.XX	± 0.1	SEE NOTE
App'd: XXX	Title: CABLE ASSEMBLY	.XXX	± 0.05	NOT TO SCALE
Date: 21 OCT. '11	Revision: 1.0	ANGLES	± 5	Unit: mm

GRADCONN
 www.gradconn.com

THIS DRAWING IS CONFIDENTIAL AND MUST NOT BE COPIED OR DISCLOSED WITHOUT WRITTEN CONSENT

Type: Cable 130 RF
CABLE 130 RF
Drawing Number:
Sheet 1 of 1
Drawing © E and O E